

SOIL & MOISTURE CONSERVATION • IRRIGATION

SMART FARMERS GUIDE

SECOND EDITION 2019



SNV

A knowledge product of:



Funded by:



Embassy of the
Kingdom of the Netherlands

Design & Layout by:
Blue Antelope Ltd

ACKNOWLEDGEMENT

First and foremost, the Smart Water for Agriculture Programme (SWA) wishes to thank the entire project team for the successful completion of this guide. The contents of this guide were compiled by Ms. Jackline Muturi with the input from the SWA core team members: Eng. Sebastian Wanjala Oggema, Dr. Abraham Mehari, Ms. Florence Kariuki, Ms. Vandana Thottoli, Ms. Bibiana Wanalwenge, David Makongo and Victor Gitonga.

Our deepest and sincere gratitude to the irrigation technology suppliers listed at the end of this guide and other key stakeholders in Kenya, who provided reference materials that formed the basis of this compilation. Their understanding, knowledge and infinite patience played a key role in ensuring that we responded to the needs of the target clients of this publication.

Special acknowledgement to the Embassy of the Kingdom of Netherlands in Nairobi who provided funding, and constructive feedback during the implementation of the Smart Water for Agriculture Programme.

Lastly, the Smart Water for Agriculture Programme activities and by extension the development of this guide would not have been successful without the cooperation and partnership of the SWA implementing consortium: SNV Netherlands Development Organisation, Aqua for All, MetaMeta, the Practica Foundation, the Royal Tropical Institute KIT and Wageningen University. Thank you all for your immeasurable contribution and support.

Thank You.

Jeen Kootstra

Country Director, Kenya and Burundi

SNV Netherlands Development Organisation

CONTENTS



**WATER
APPLICATION**

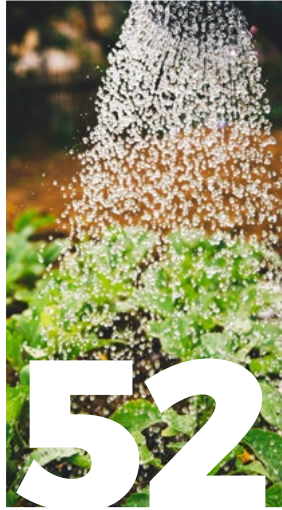

APPLICATION



**SOIL AND
MOISTURE
CONSERVATION**



CONTACTS AND OTHER INFORMATION RESOURCES

GENERAL INFORMATION

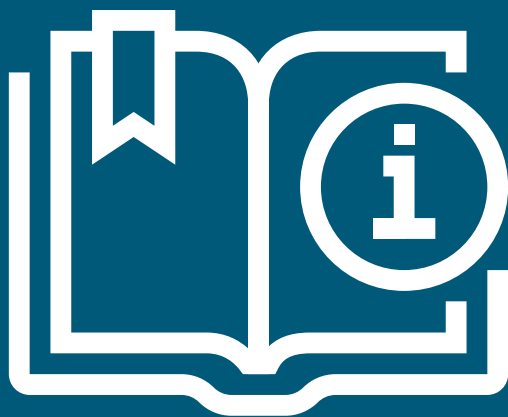

HOW TO USE THIS GUIDE

INTRODUCTION

Climate change, unpredictable weather / rainfall patterns has increased demand of irrigation water to ensure crop/agricultural productivity.



ABSTRACTION AND STORAGE

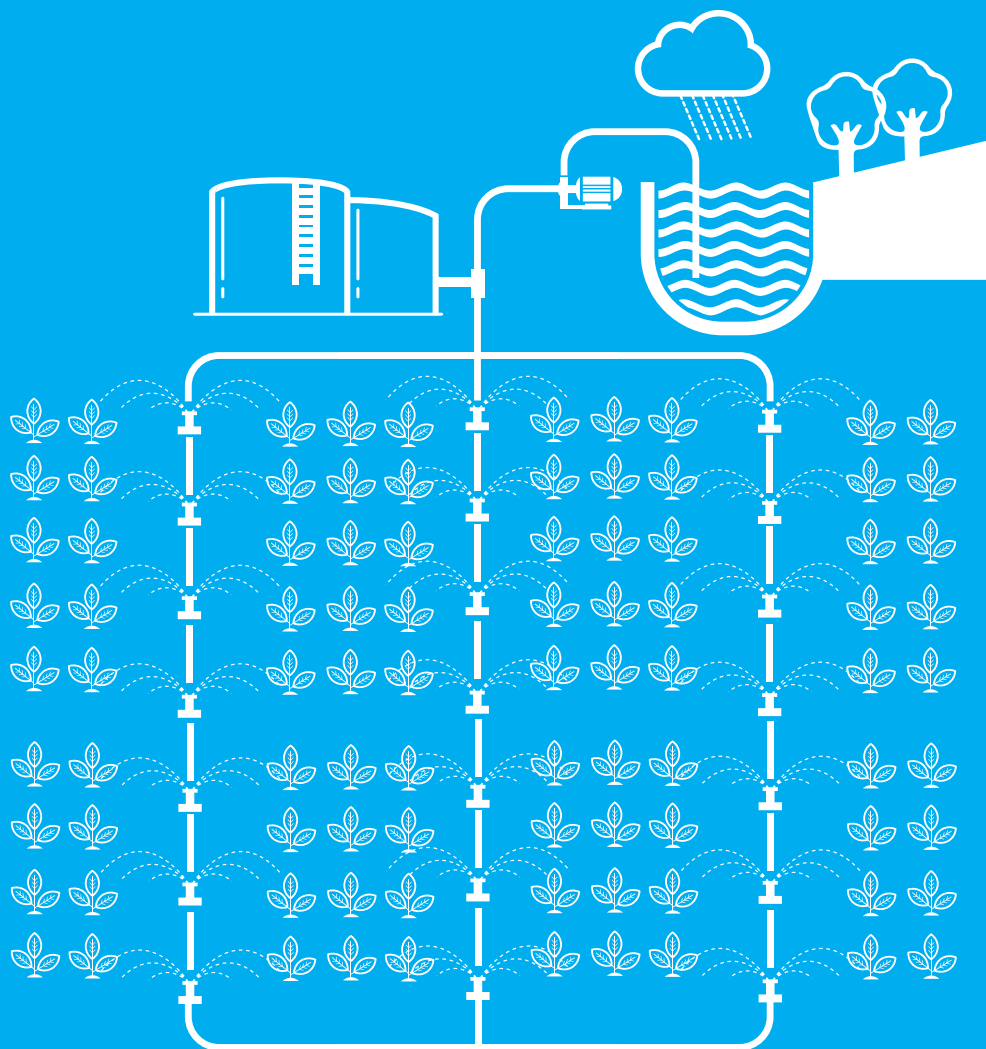

WATER STORAGE

DEFINITION

Water Storage is the act of keeping water on or off the farm for use during the dry season when there is no rainfall or when other water sources are scarce or not available

Water storage solutions are the different types of technologies which enable farmers to keep water on or off the farms for use during the dry seasons

These solutions help farmers collect and 'keep' water when it is plentiful and make it available when it is scarce

Importance of storage

Water storage helps the farmer to 'keep' sufficient water for supplementary irrigation when needed.

Factors farmers consider when selecting storage solutions

A storage solution should be easy and cost-effective to construct, it should also hold sufficient/required quantity of water and this water should be easily available/removable from the storage technology

Some of the factors influencing choice /selection of storage solutions include

- (a). Volume of water required: the volume of water required to be stored is determined by the land size, duration dry season and availability and quantity of alternative sources during the dry season.
- (b). Source of water for storage: there are different sources of the water to be stored, these are rainfall runoff, roof rain water harvesting, river flood flows etc. and they affect the storage solution selected
- (c). Alternate water sources available
- (d). The intended use of stored water: different uses will require different quality of water. Irrigation only can have open storage but other uses like livestock and household uses may require closed/covered storage solutions
- (e). Cost and availability of storage solutions: the cost of available solution will have an impact on which storage solution a farmer will select

- (f). Knowledge of the existing storage solutions: knowledge / information on available solutions will have an impact on which storage solution a farmer will select

TYPES OF STORAGE

Storage Tanks

Tanks may either be masonry, steel aluminium/mettalic or plastic tanks. For the same m³ tank capacity, masonry tanks are considered cheaper and longer lasting than the plastic tanks.



Water pans/ponds

Excavated ponds/pans are small reservoirs, about 1 m to 3 m deep, usually dug of-stream with raised and compacted banks all around. Usually, they are constructed to collect and store runoff water from various surfaces including from hillsides, roofs, roads, rocky areas and open rangeland.



ELEVATED STORAGE

- ✘ It is possible to store the water at a certain elevation, so that you will have enough pressure to keep on using your application system.
- ✘ A good option for this is to install a plastic tank, because of its low weight. The cost of a polytank is about 10 000 KES (\$100) per 1000 litres, and their lifetime is about 10 years.
- ✘ The elevation tower can be made of wood, concrete or steel, and costs depend on the material and the height.
- ✘ It is recommended to keep the level of the storage tank lower than 4 m.
- ✘ It is important to fix the tank firmly to the tower: when the tank is empty, strong winds may blow it away.



GROUND STORAGE

- ✘ Ground storage is a low-cost alternative. Keep in mind that the water can only flow into your application system if your field is situated lower. You can also use watering cans if the storage basins are on the field.
- ✘ The construction of a ground storage in brick masonry costs about 10 000 KES (\$100) per 2000 litres; cheaper options without bricks go for 5 000 KES (\$50) per 2000 litres reservoir.



POND LINING

POND LINING MATERIAL FOR WATER STORAGE



The pond liner is a Geo-membrane material used to prevent water loss through seepage in ponds. It holds water in ponds to meet future water demands.



PROPERTIES:

- ✘ **Type:** High density polyethylene (HDPE) Geo-membrane
- ✘ **Gauge:** 0.5mm and 1mm
- ✘ **Widths available:** 0.5mm - 8m
1mm - 7.5M
- ✘ **Warranty:** 0.5mm -Minimum warranty of 10 years.
1.0mm -Minimum warranty of 20 years
- ✘ **Resistance:** Highly resistant to tearing and puncture and is treated against solar degradation. It also has excellent chemical resistance to organic and inorganic solvents
- ✘ **Compliance:** Full compliance with UNE 104300 – GM13 and EN ISO standards.
- ✘ **Uses:** To cover farm pond of various sizes to hold water and is suitable for both small and large scale farmers. Holds water from various sources; runoff, pumped water, etc.

METHODOLOGY

- 1 **Pond excavation;** can be done manually or by use of an excavator



- 2 **Installation of the dam liner**



3 Water storage



DO's for the farmer

- The farmer does the excavation works of the pond before delivery and installation of the lining material. The excavation can be done manually or mechanized.
- It is advisable that the farmer fences the pond after installation to avoid access by animals; convey the water from the pond by pumping other than manual withdrawal using buckets etc.



DO's for the company

- Supply and installation of the pond lining material
- Training the farmer on how to handle the material
- After sale services i.e. repairs incase of any damage



We offer advice on how to excavate the farm ponds and where to locate the farm ponds within the farm depending on water requirements and in the best way that suits the farmer's demands.

WATER ABSTRACTION

Water abstraction is the removal of water, permanently or temporarily, from water bodies such as rivers, well, springs, water pans, reservoirs for Irrigation, domestic use, watering livestock, industry and so many other uses.

The need for supplemental irrigation or total irrigation calls for abstraction of water from water sources or storages.

PRODUCTS OVERVIEW

The water abstraction technologies available in the Kenyan market include;

1. **Pumps.** These include solar pumps, electric pumps and fuel pumps
2. **Gravity methods.** In this water may flow from a pan/tank to the farm depending on the elevation of the pan. This is possible if the elevation of the water storage structure is higher than that of the farm.

Some specific products are as discussed in this product manual.



FACTORS FOR FARMERS TO CONSIDER FOR ABSTRACTION OF WATER

- ✘ The water capacity of the source, amount of water in a reservoir or discharge from the river.
- ✘ Amount of water required, to be abstracted from the source. The demand for water varies over time and depends on the types of crops, crop growth stages and on the climate.
- ✘ The license or permits of abstraction from WRA, permission of abstraction depend on the amount of water required before you are given a go ahead by the regulator.
- ✘ The methods of abstracting water from the sources; these can be by gravity or pump lifting.
- ✘ The storage capacity that is available to store water for a particular period.

TYPES OF PUMPS

Broadly, pumps are classified as either surface pumps (designed to pump water from surface sources like springs, ponds, tanks, or shallow wells max. 7 meters deep) or submersible pumps (designed to pump water while submersed in the water source). While solar pumps and electric pumps are either submersible or surface pumps, most fuel pumps are surface pumps. These are described as follows;

Solar Pumps A solar-powered pump is a pump running on electricity generated by solar panels or the radiated thermal energy available from collected sunlight as opposed to grid electricity or diesel run water pumps. Their advantage is that they can pump water in areas without power line connections and that though the initial investment to purchase them is high, the operational costs are lower as they only require sunlight to be powered. In addition, they are simple and easy to install and operate.

Electric Pumps An electric pump is one that is powered by grid electricity. They are relatively cheaper to buy as compared to solar and fuel pumps but require higher operational costs as compared solar pumps because the cost of electricity is high. However, they cannot be used in areas where there is no connection to electricity grid lines.

Fuel pumps Being the most commonly used in Kenya, they are readily available for purchase but require higher maintenance and operational costs as compared to solar pumps.

HOW TO CALCULATE STORAGE REQUIREMENTS AND COST CONSIDERATIONS

In Kenya, it is required that the amount of storage should be large enough to hold sufficient water for a farmer to irrigate for the three dry months when there is no rainfall. Other factors that determine the size of storage required include;

- 1. Size of irrigated land.** The larger the size of irrigated land, the more the bigger the size of storage required. Indicative storage for sample irrigated farm sizes without rainfall are as follows;

Irrigated land Size (acres)	Storage requirement (m3)
0.25	480
0.5	960
1.0	1,925
2.0	3,850
5.0	9,600

- 2. Method of water application.** Water saving water application methods like drip systems are considered to consume less water as compared to use of sprinklers and furrow irrigation. Therefore, water storage needs will be higher if furrow irrigation is the method of water application that a farmer chooses to use
- 3. Piped inflows.** Even in the absence of rainfall, a farmer will need lesser storage if there is piped irrigation water in his/farm. This is because this water can also be used to cater for the crop water needs.



PUMPS



ALL YOU NEED TO KNOW WHEN BUYING A SOLAR IRRIGATION PUMP

Check out the NEW Solar Irrigation Pump Selector (SIPS) app for your smartphone and learn more on available pumps for your farm.



WHY CHOOSING SOLAR PUMPS?

A wide range of solar pumping solutions are on the market to irrigate up to 1 acre (4000 m²). But how to select an affordable solar pumping package for your farm?

Learn about the implications of your water source, pump, field dimensions, storage options and efficient applications to bring the water to the crops.



- ✘ Free energy from the sun
- ✘ No noise, bad smell or pollution
- ✘ Easy to operate
- ✘ The stronger the sunshine the larger the flow of water... and that's exactly when the plants need it!
- ✘ Can be used for other purposes like charging mobile phone or batteries



CONSIDERING INVESTING IN A SOLAR PUMP?

Buying a small solar pump set is a significant investment and ranges between 30 000 KES and 200 000 KES (300 USD & 2 000 USD).

- ✘ It reduces the production cost by 30-60% because no fuel is needed and maintenance costs are much lower.
- ✘ Compared to manual pumping such as treadle pumps or simple rope and buckets, solar pumps will allow you to increase the irrigated size of the land and save significantly on labour costs and labour efforts.

Within 2 to 5 growing seasons, investment costs for solar pumping can be fully recovered.

	Solar pumps	Fuel pumps	Manual pumps
Price	More expensive	Less expensive	Cheapest
Running costs	Very cheap	Expensive	Very cheap
Maintenance	Very little	More often	Very little
Lifetime	3-10 years*	3-5 years*	3-5 years*
Maximum plot size	Less than 1 acre (< 4000 m ²)*	More than 2 acres (> 8000 m ²)	Up to 0.2 acre (< 800 m ²)
Pumping time	Daytime only	Can be always	Can be always
Power, pressure, flow	Low	High	Lowest
Typical use	Let it pump the entire day	Only when you irrigate or fill a tank	After 2 hours you get tired
Not suitable for	High pressure sprinklers. Hose and furrow irrigation.	Small pipe diameters.	Spray tubes, sprinklers, furrows, filling elevated tanks
Very suitable for	Low pressure water application such as drip, spray tube, mini pivot. Filling a (low) storage tank	Hose, spray and furrow irrigation. High pressure sprinklers. Long distance pipes.	Hose irrigation. Small gardens.

IT'S NOT ALL THAT SUNNY!

Water supply depends on sunshine:

- ✘ Solar pumps only operate during sunshine hours, not in early mornings nor late afternoons
- ✘ When there are clouds the pump works less hard!

Solar pumps work slower:

- ✘ It takes about 8h to get what a fuel pump would irrigate in 1h.
- ✘ Because of that most solar pumps can only irrigate 0,25 to 0,5 acre (1 000m² to 2 000m²)

Solar pumps have less power, water flow and pressure:

- ✘ It requires changing irrigation practices & alternative application methods
- ✘ Investment is needed for storage or efficient irrigation packages

HOW TO SELECT A SOLAR IRRIGATION SOLUTION?

STEP 1: SELECTING THE TYPE OF PUMP

	Suction pump	Submersible pump
Placement	Next to the water source	Inside a borehole or hand dug well, below the water
Maximum water depth	7m maximum	15 - 40m depending on pump
Usually applied to	River, stream, pond Hand dug well, borehole (<7m)	Hand dug well, borehole (>7m)
Type of installation	Generally portable All fuel pumps are suction pumps	Generally fixed



CHOOSE YOUR PUMP DEPENDING ON:

- ✗ Source of water
- ✗ Total pressure and volume of water needed
- ✗ Price
- ✗ Repairing and replacement of parts
- ✗ Resistance to silt/sand in the water
- ✗ Transportability

STEP 2: CHOOSING THE SPECIFICATION OF YOUR PUMP

The Total **Pressure Head** is the sum of.

1. The water depth is the depth of the water surface measured from the ground surface where you are standing. Make sure you take the actual depth during pumping, preferably after several hours of pumping when the water level is low.
2. The height is the difference in land elevation between the water source and your plot.
3. Pipe pressure is the force needed to push water through the pipes until it reaches the field. The smaller the pipe diameter, the more pressure you need.
4. The application pressure is the pressure needed by the application method, such as sprinklers.

The height is the difference in land elevation between the ground surface at the water source and your plot.



You can reduce the total pressure head in the following ways:

- 1 When you use a tank, do not put it very high
- 2 Use an application method that works with low pressure (e.g. spray tubes)
- 3 Use large diameter pipes (min 32 mm) to transport your water to the field

The flow indicates how many acres you can irrigate.

- ✗ Your application method also influences how much you can irrigate. With furrow irrigation you lose more water than spray or drip irrigation.
- ✗ Some brochures give the flow in Litre/minute other in Litre/hour. Multiply the L/min by 60 and you get L/h. Multiply this by 6 and you get the Litre/day.



The higher the total pressure head the lower the water flow. When the pressure head of your system increases, the pump will give much less water than the Max Flow indicated on the pump.

STEP 3: SELECTING YOUR POWER SOURCE



SOLAR PANELS:

- ✗ The size of the solar panel is expressed in Watt-Peak (Wp) generated at full light.
- ✗ More solar panels = More power = More water
- ✗ Solar panels' lifetime is up to 20 years. When you will change the pump you will be able to keep the same solar panels!



BATTERIES:

- ✗ They make your pump work more hours
- ✗ They give a more constant flow
- ✗ BUT they are NOT recommended:
 - Expensive
 - Short life time
 - Heavy to transport
- ✗ It is more useful to invest in water storage Do NOT use car batteries because they are not made for solar applications. Better use "deep cycle batteries".

STEP 4: SELECTING AN APPROPRIATE APPLICATION METHOD

Water application systems are an important choice. They determine your water use efficiency, or how much of the water will be used by your crop.

High water saving
+
Low pressure
system

You can irrigate a larger
area with the same pump



Here are some important criteria to consider when choosing your application system.

A green box means it is optimal for usage with solar pumps.

	Drip	Misters & spray tubes	Low pressure sprinkler	Mini Pivot	Hose or pipe 32 mm	Furrow / Basin
Water saving	Very high	High	Medium	High	Medium	Low
Pressure needed	Low	Medium	High	Low	Very low	Very low
Labour time needed	Very low	Low	Medium	Low	Very high	Very high
Price indication² (KES) (for ½ acre)	96 000 (\$950 ³)	58 000 (\$ 570)	30 000 (\$ 300)	30 000 (\$ 300)	18 000 (\$ 180)	7 000 (\$ 70)
Lifetime	2 - 3 years	4 years	5 years	5 - 8 years	5 - 8 years	N/A

1. N/A: Not applicable
2. Price indications are based on a complete system including tubes, hoses and connections.
3. There are many types of drip systems on the market of different qualities and with different characteristics.
Price based on Netafim drips kit



Drip



Hose pipe



Mini-Pivot



Spray tube



Low pressure Sprinkler



Furrows

STEP 5: DO I NEED WATER STORAGE ?

During the **early morning** and **late afternoon** the sun does not have much energy, so the water flow from solar pumps is low. If you use a hosepipe or furrows it will take longer to irrigate. If you use sprinklers or spray tubes the water may not be distributed evenly.

At this time of the day a reservoir can be used to store the water for later. Keep your storage low so that your flow does not reduce too much. The stored water allows you to irrigate faster than the pump flow, at a convenient time.



Keep in mind that **elevated storage is not obligatory** when using a solar pump! You can also chose for low pressure application systems like drip or mini pivots, or use ground storage basins.

STEP 6: CHECKLIST BEFORE BUYING

Use the following check list to make sure you know all the advantages and disadvantages of the pump of your interest.

- The pump is suitable for my water source and depth
- The pump gives enough water looking at the total pressure head of my system
- The pump gives enough water for the size of my field
- I know the pump efficiency and number of solar panels needed
- The lifetime of the pump is sufficient for the investment I make
- The pump is resistant to the amount of silt in my water source
- I have checked the risk of damage caused by dry running of the pump
- My place is secure or I can take the pump and panels home
- The pump has a guarantee and I know what is included
- I know if the pump can be repaired and where I can find spare parts
- The complete price is good and I know what is included

STEP 7: BUYING A PUMP

FINANCE SOLUTIONS

Solar pumps demand a relatively high initial investment, but it pays off on the long term. Several suppliers offer a finance solution that allow you to pay back over time. This can help you to take the step to solar irrigation. Find out the answers to the following questions first:

- ✘ Which suppliers offer a finance solution? How much does it cover?
- ✘ What are the requirements to get access it?
- ✘ Is it a leasing/renting arrangement or do I become the owner of the pump after paying back?
- ✘ What are the pay back periods and how much interest do I pay?
- ✘ How can I make the payments?
- ✘ What happens if I cannot pay timely?

WHERE TO BUY A SOLAR PUMP?

Via Internet

You can order many pumps with their motors via internet, for example via alibaba.com. For this, often you need a credit card and post address.

Advantage:

- This may be much cheaper than buying a complete solar pump set at a local dealer.

Disadvantages:

- It is difficult to get service or guarantee.
- It is also difficult to know their quality, specifications and lifetime.
- Pumps without a known brand are generally cheap, but may have a short lifetime. (1-3 years, depending on how intensive their use is).
- You will have to figure out yourself how many solar panels you need of what voltage and power, and buy them separately.

In-country, local and national dealers

It is recommended to buy from a dealer that offers after-sales service. You may visit several dealers to obtain further advice and compare prices.

STEP 8: START USING YOUR PUMP

Solar pumping changes the way you irrigate.

Here are some best practices when using solar pumps:



All day operation: The best use of a solar pump is to let it run the entire day. It pumps silently and quietly. This yields the maximum amount of water.

Use your water wisely: Solar irrigation is best combined with efficient water application techniques. Furrow irrigation does not use water efficiently. This will decrease the plot size that can be irrigated.

Low pressure application: A low-pressure distribution and application system is the best option for solar pumps. A drip system, min-pivot, low-pressure (butterfly) sprinklers or spray tube. Most high pressure sprinklers will not work at all or at a minimum output. And the extra pressure needed to operate high-pressure sprinklers means that the pump will deliver less water.

Smart transportation: Use large diameter pipes (minimal 32 mm) to transport the water, especially over longer distance. This will result in less friction losses and a larger flow compared to small diameter pipes and hoses. An example of smart transportation are buried PVC pipes.

Labour: Using a solar pump directly with a hose and sprayer will take a lot of time to irrigate a plot, because the flow is relatively small. If you use a hose, first fill a tank and spray from the tank.

Marketing: You will need to sell some of your produce on the market, so that you can earn back your investment.

DIGITAL TOOL FOR FARMERS: SOLAR IRRIGATION PUMP SELECTOR

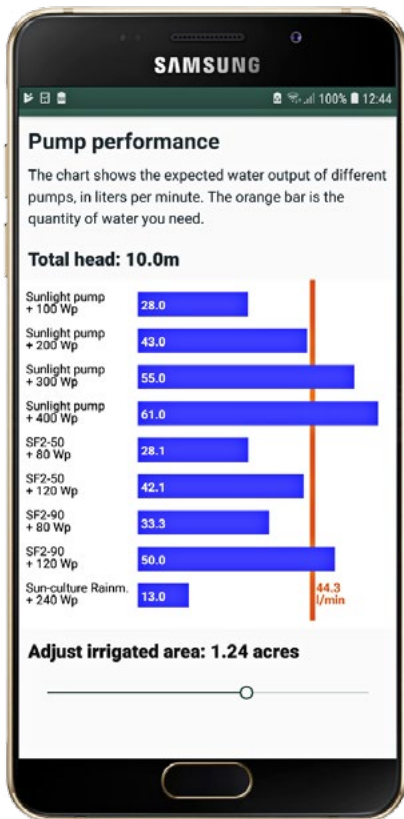

Every farm is unique in terms of its location, size of the irrigated plot, crop, terrain, water source and irrigation method. PRACTICA Foundation developed a simple smartphone app to calculate which solar pumps fit your situation.

It is a tool to estimate the amount of water you need and the total required pressure head. As a result it shows which pumps are suitable for you.

You can download it in the Google Play Store, looking for “Solar Irrigation Pump Selector” (SIPS).

SUNLIGHT PUMP

URNS SUNRAYS INTO SAVINGS

A highly efficient, solar-powered water pump for small to medium irrigation and domestic water supply in developing countries.



MAIN FEATURES



User-friendly controller



Highly efficient motor



Robust pump head



The pump is supplied with 10m of high quality suction pipe and all the fittings, a panel and the connection cables up to 15 meters.

PRODUCT SPECIFICATIONS

- 1 **Discharge capacity** of max. 45 litres/min or around 18'000 litres/day while running on solar and 50,000 liters per day if you extend pumping using a battery.
- 2 **Vertical water lift** up to 40 meters
- 3 **Modularity:** 100 - 500W panels required depending on specific needs of user (water lift and daily amount of water required)
- 4 **Flexibility:** can be used with a solar PV panel and/or a battery
- 5 **Portable design:** L575mm x W200mm x H270mm, 14 kg
- 6 **Warranty** 2 years
- 7 **Fully automated** system with sensors to avoid running dry of the pump and tank overflow.
- 8 Like every **surface pump**, the sunlight pump pump has a maximum suction depth of 7 metres (21ft) at sea level



USES

The sunlight pump is an ideal fit for drip irrigation and sprinklers. The most productive use of water is recommended.

OTHER USES APART FROM IRRIGATION

Other possible applications are water provision for livestock or water circulation in fish farming, drinking and domestic water supply.

WHY THIS PUMP

- ✗ Easy to install, use and maintain
- ✗ Pumps up to 18'000 liters of water per day without any physical effort compared to hand pump
- ✗ High quality & longevity
- ✗ Portable – one pump for multiple sites
- ✗ Free source of energy - Once paid off, no running costs compared to diesel pumps
- ✗ Long lifespan and very minimal repair and maintenance costs compared to diesel pumps
- ✗ Higher income and quality of life for the family
- ✗ Zero CO² emissions environment-friendly and safe technology
- ✗ Extensive support during design, installation and use of the pump by trained technician

PUMP COMPONENTS

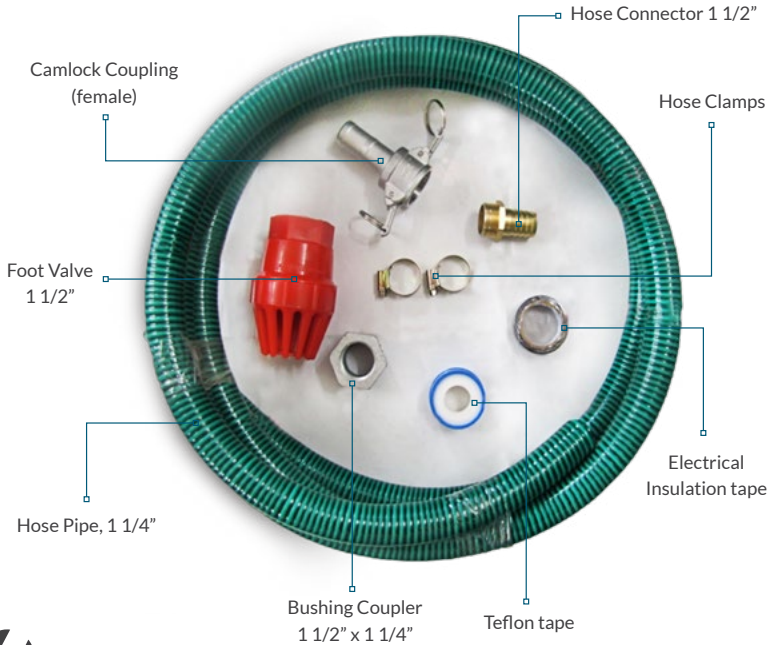

Each sunlight pump is delivered with all the accessories required, including high quality suction hose and connectors and is installed by a qualified technician from Greenserve Agrisolutions.

INSTALLATION GUIDE



1

Hose fixed to camlock connector



2

Priming the pump



3

Connecting hose to the pump

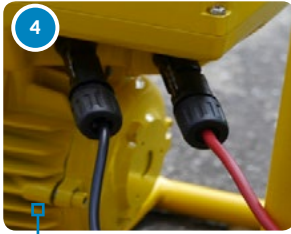

4 Connect power cables to the pump



5 Hoses connected to the pump



6 The user controller interface



1 **Hydraulic connection:**
standard camlock connectors for easy and tight fit.



2 **Electric connection:**
standard MC4 connectors for safe connection to a solar PV panel or to a battery



3 **LED user interface:**
Allows to change between solar panel and battery mode, to monitor the performance of the pump and for on-site problem solving (indicates warnings and errors).

USE CASES

You can design your own pumping system with the sunlight pump configurator tool:
www.ennos.ch/configurator

Legend for the pictures:

- A** = Suction depth in meters
- B** = Vertical lift from the pump to the highest point
- C** = Total lift (geodetic or static lift, A+B)
- D** = Horizontal distance between pump and tank
- E** = Horizontal length suction line

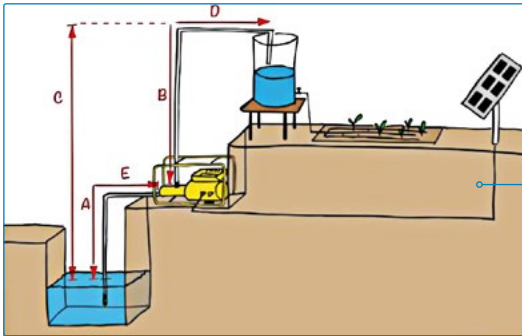

Standard application

The standard application is mostly used for crop irrigation. Ground water is pumped and fed to irrigation system or drinking water system. (Overhead tank is optional)

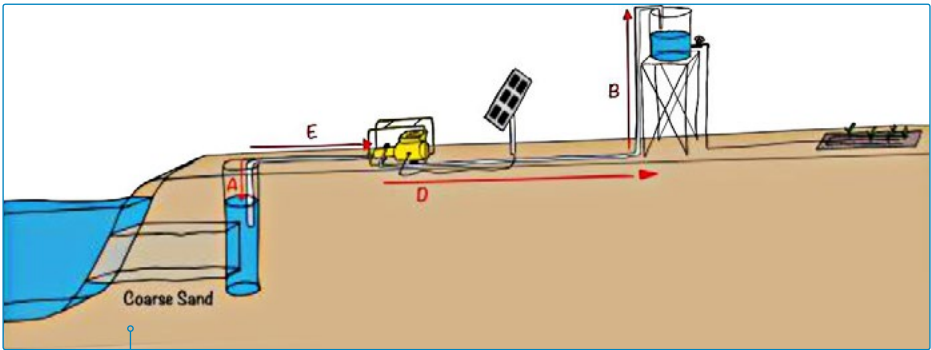

Water from lake application

This application requires a well or so-called “suction pit” next to the open water source.

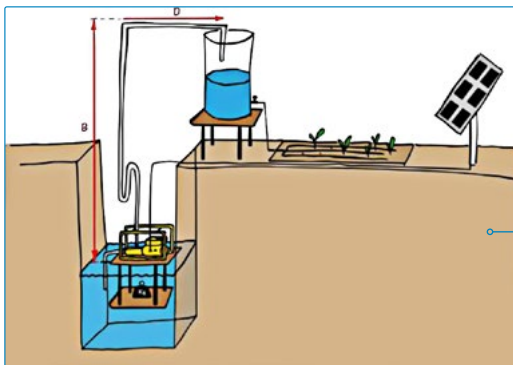

Deepset floating application

If the suction depth is bigger than the maximum 6 meters at sea level, the pump is lowered down into the well to get it closer to the water source. The pump can be put on a floating platform which goes up and down with the water table. Always make sure that the pump is not immersed into the water. The float should be equipped with legs and some ballast below the water surface (centre of gravity below level will prevent tipping over).



The suction hose should be over the leg ends to avoid sucking up mud from empty well.

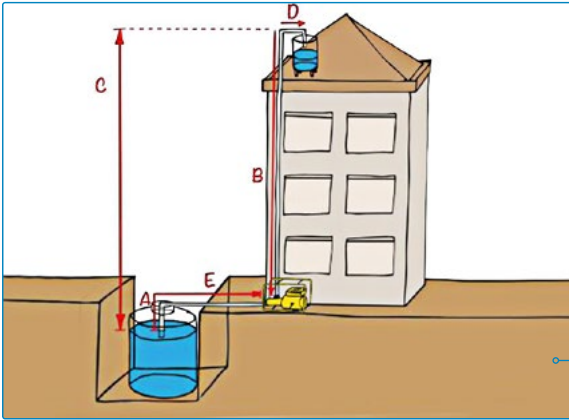

High-rise building application

This is an application where water is pumped into a tank on the roof of a multi-storey house to supply several families with household water.



REPAIR AND MAINTENANCE

- ✘ Every pump is installed and serviced by a qualified technician who is the first contact for the user in case of a problem.
- ✘ The user is instructed how to properly use and store the pump. He or she is also equipped with a user manual.
- ✘ The sunlight pump Android app allows to monitor the pump performance and to diagnose problems on site.

Sunlight pump app available for free download in the Google Play store.





DO's

- Go through the user manual provided
- Register warranty in the steps outlined in the user manual
- Prime pump (put water in pump) Before reconnecting the suction and pressure hose
- It is an automated system



DON'Ts

- Connect extra panels to the pump without instructions from Greenserve technicians
- Connect the hose with anything else than the connectors delivered
- Submerge the pump inside the water.
- Connect the pump to electricity

SF2 SOLAR IRRIGATION PUMP SYSTEM



MAIN FEATURES

The Futurepump SF2 is a solar powered irrigation pump designed to work with shallow water sources and capable of irrigating up to 1 acre (depending on crops and irrigation methods).

The pump is of a very robust design and withstands the rigours of everyday work on a farm. It is a portable device that comprises of two parts, the pump, and separate solar panels, this makes it very easy to carry and move around the farm.



Pump is supplied with;

- ✘ High quality suction pipe
- ✘ User spares pack
- ✘ FIVE years warranty
- ✘ Delivery and installation



PUMP SPECIFICATIONS

- 1** The SF2 is a reciprocal piston pump capable of drawing water from a maximum depth of 7 m.
- 2** It can produce a total lift of 15m, (i.e. if the water source is 6 m down it will lift the water a further 9m giving a total lift of 15m).
- 3** SF2 comes with the 80 W configuration but there is an option to upgrade to 120 W
- 4** On and off switch for simple operation

OTHER USES APART FROM IRRIGATION

- ✘ Watering livestock
- ✘ Aerating fishponds / aquaculture
- ✘ Domestic purposes

WHY SF2 IS UNIQUE

In a sector that is rife with unreliability from small irrigation pumps, both petrol and solar, there is now a pump that is so robust that the manufacturers, Futurepump Ltd, are confidently supplying it with a full five-year warranty.

- ✘ The solar irrigation market is starting to get infiltrated by cheap, poor quality imports that are unable to handle the environment found on a typical Kenyan farm. Mud, sand, grit and running dry etc all mean significant problems to substandard submersible pumps, but the SF2 has no problem handling whatever it finds in a Kenya farm water supply.
- ✘ Reliance on rainfall can cause serious losses for the farmer with the unpredictable weather patterns. Farmers using petrol pumps are stuck with expensive recurring costs. The SF2 allows smallscale farmers to save on fuel costs and increase income with limitless seasons since the pump relies on free solar energy.

PUMP COMPONENTS



BENEFITS OF THIS TECHNOLOGY

- ✘ No fuel or electricity costs
- ✘ Robust, and farmer-fixable (as simple as a bicycle)
- ✘ Designed with easy maintenance in mind
- ✘ Pumps enough to irrigate around an acre
- ✘ Ideal with tanks, sprinklers, hoses or drip systems
- ✘ Removable, folding PV panels reduces theft risk
- ✘ Supplied with 80W panel, upgradable to 120W
- ✘ Solar panel tilting system for best performance
- ✘ No damage caused by dry pumping
- ✘ Tolerant of grit, sand, mud and debris
- ✘ 5V USB charging socket for phones

INSTALLATION GUIDE

SOLAR PANEL



1

Unpack the Solar Panel from box together with it's panel support (1).



2

Attach the panel support (2) on the side of the panel and secure it with the washer & nut (3).

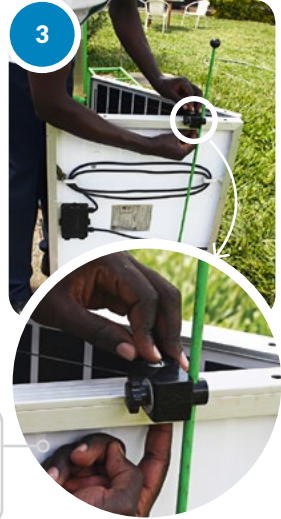

3



4

Spread open (4) the Solar Panel as seen and the tilt it as seen on (5).



5

Clear area away from shade to allow direct sunlight to get to the solar panels



6

Plug the panel into the low switch box socket (6).



Ensure the plug grooves align (7).

HOSE CONNECTION



Attach the blue filter (8) to the inlet hose (the end going into the water)



Connect the inlet (9) and outlet (10) hoses to the hose nipples, if necessary secure these using the hose clamps provided.



11

Ensure all the connections are secured.



12

Flip the switch to the **ON** position.



HOW IT WORKS

The SF2 has two 40Watts panel connected in parallel **to convert sunlight into electrical energy**; **the motor**, a specially designed DC motor to use the electrical energy to turn the flywheel; and **the pump**, a reciprocal piston pump to draw water out of a well, river or lake.

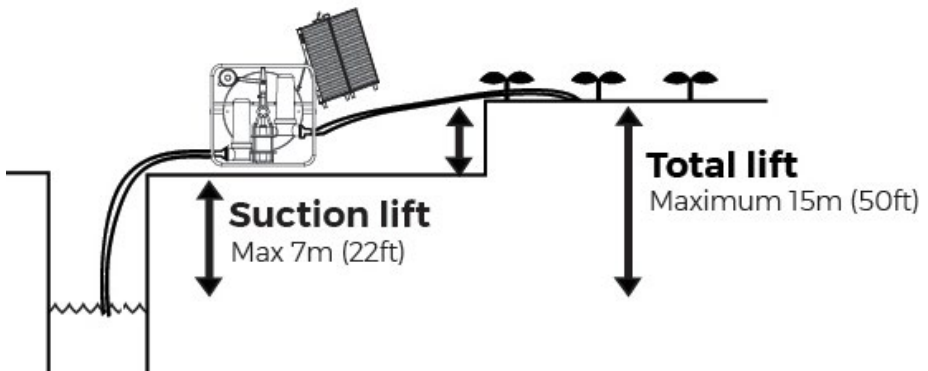

At shallow heads, the Futurepump SF2 can deliver up to 1 litre per second, which is 3,600 litres/hour or over 21,000 litres per 6-hour pumping day (120W input).



DO's

- Go through the user manual provided
- Register warranty in the steps outlined in the user manual
- Prime pump (put water in pump) each time before starting it
- Always switch off the pump when you finish using it



DON'Ts

- Connect extra panels to the pump (unless it is supplied by Futurepump's stockists)
- Use hoses with a diameter less than 1" (32mm)
- Use the pump for depths over 7m

RainMaker SOLAR WATER PUMP



RainMaker is a high efficiency positive displacement diaphragm submersible solar water pump.

The system is designed for off-grid households in Africa, Asia and Latin America as a near zero recurring cost replacement for diesel, electric and manual water pumps used for irrigation, livestock and household water supply.



USES

- ✘ Irrigation
- ✘ Livestock
- ✘ Household use

MAIN FEATURE

The RainMaker is a solar submersible pump that is powered by the the sun to pump water from any water source (wells, dams, boreholes, rivers or underground tanks etc). The RainMaker has the following advantages

- ✘ It utilizes power from the battery hence can operate with stable output even when there is cloud cover with the batteries sufficiently charged.
- ✘ It is lightweight and portable.
- ✘ Reduced operation cost. No extra cost like fuel is required once the system has been purchased
- ✘ Its affordable hence preferred by a majority of the small scale farmers for home use and/or farming.
- ✘ Easy operation. The RainMaker has a plug and play capability hence easy to understand and use.

PRODUCT SPECIFICATIONS



a) RainMaker Solar Pump

- ✘ Maximum head: 100m
- ✘ Discharge: Can pump up to 6,000 liters of water per day Rated Voltage:24V
- ✘ Maximum Voltage: 30V
- ✘ Weight: 4.3Kg
- ✘ Can pump up to 6000 liters



b) Battery Pack

- ✘ 2 Portable Deep cycle lead acid batteries, 18Ah each. Total 480WH-24V
- ✘ Charge Controller.
- ✘ Battery has non spillable construction design, sealed and maintenance free.



c) Solar Panels 120W

- ✘ 2pc solar panels
- ✘ Power: 2 x 60W
- ✘ Voltage: 2 x 18V
- ✘ Current: 3.3A



- d) 100m HDPE pipe or
50m HDPE pipe + 20m flexible pipe

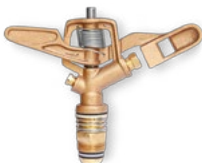

e) ½" Steel brass Sprinkler



f) Butterfly Sprinkler

OTHER USES APART FROM IRRIGATION

Can be used with all types of irrigation techniques including drip kits, sprinklers and water tanks. Apart from irrigation the RainMaker can also be used for;

- ✘ domestic purposes, lifting water to overhead tanks
- ✘ fish farming, aerating fish ponds



HOW IT WORKS

The kit is designed to pull water from any water source (Lake, river stream, well, borehole, water harvester etc.) using solar power.

The solar panels provide the pump's power directly without the need for expensive batteries or inverters. Water is pumped in to a raised water storage tank during the day.

When irrigation takes place, a valve on the water tank is opened and water flows down through a filtration system and onto crop root zones via drip irrigation tape.

BENEFITS OF THIS PUMP

The RainMaker is a solar submersible pump that is powered by the the sun to pump water from any water source (wells, dams, boreholes, rivers or underground tanks etc). The RainMaker has the following advantages

- ✘ It utilizes power from the battery hence can operate with stable output even when there is cloud cover with the batteries sufficiently charged.
- ✘ It is lightweight and portable.
- ✘ Reduced operation cost. No extra cost like fuel is required once the system has been purchased
- ✘ Its affordable hence preferred by a majority of the small scale farmers for home use and / or farming.
- ✘ Easy operation. The RainMaker has a plug and play capability hence easy to understand and use.

PUMP COMPONENTS

Solar Panels



2 Portable Deep cycle lead acid batteries, 18Ah each.
Total 480WH-24V
Charge Controller.
Battery has non spillable construction design, sealed and maintenance free.

Pump

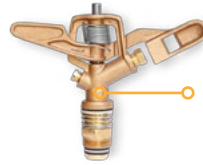

1/2" Steel brass Sprinkler



Connector Kits



HDPE Pipe - PN6 20mm-100m
100m length, 20mm diameter
Conveys water from the pump
to the sprinkler or storage tank.

INSTALLATION GUIDE

SOLAR PANEL

1



Unlock and open the portable Solar Panel

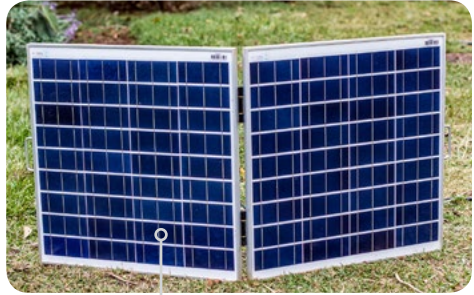

Confirm there is no cracks on the panels. This may occur during transportation.

2



Connect the panels as shown on (2)



3



The connection should be as shown.



(A) MC4 Male Connector
(B) MC4 Female Connector

BATTERY PACK



- The battery in use are valve regulated lead acid batteries. It is **recommended that you charge immediately after discharge to retain battery life.** It will be packaged as shown in the diagram.

DISPLAY ICON SYMBOLS

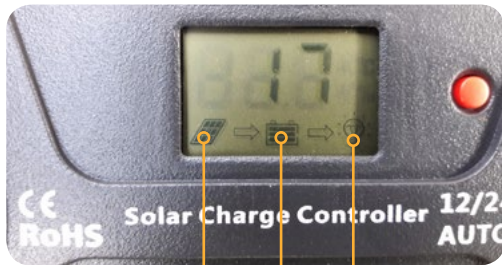

The **1st icon** indicates that the **panels are connected.** When the panels are disconnected, this icon disappears.

The **2nd icon** indicates that the **battery is connected.**

The **3rd icon** indicates whether the pump is running or not. When the **bulb is lit, the pump is running.**

SOLAR PUMP

1 Test Pump



(A) Make a temporary connection to the pump as shown in the diagram below to confirm if the pump is working. It should run for less than 10 seconds.

(B) Connect to the battery pack and see if the pump will run. (The white and black wires are temporarily joined)

2 Connection

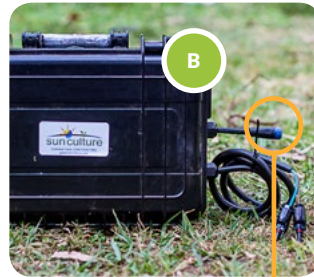

(A) Connect the M15 pump cable to the **(B)** M15 connector on the battery and then secure and tighten the M15 connection **(C)**



3 Pipe Connection

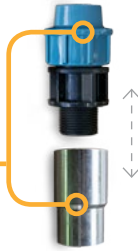

Water outlet

Connection as captured above

4 Pump Water



Pump placed or dipped into water source.



connection from pump to outlet
sprinkler or drip kit.



Solar power connection from pump

HOW IT WORKS

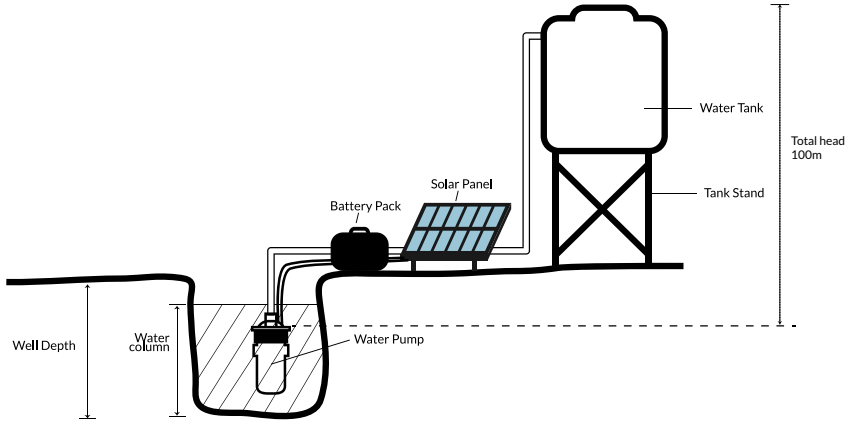

DO's

- Go through the user manual provided
- Register warranty in the steps outlined in the user manual
- Prime pump (put water in pump) each time before starting it
- Always switch off the pump when you finish using it



DON'Ts

- Connect extra panels to the pump (unless it is supplied by the pump's stockists)
- Do not leave the battery exposed to direct sunlight or stored where there is heat

- 1) Drip and Mist Irrigation systems from 1/8th of an acre to large acres of land
- 2) Solar powered AC and DC pumps for large scale farming/irrigation
- 3) Agronomy support
- 4) After-sales services

APPLICATION

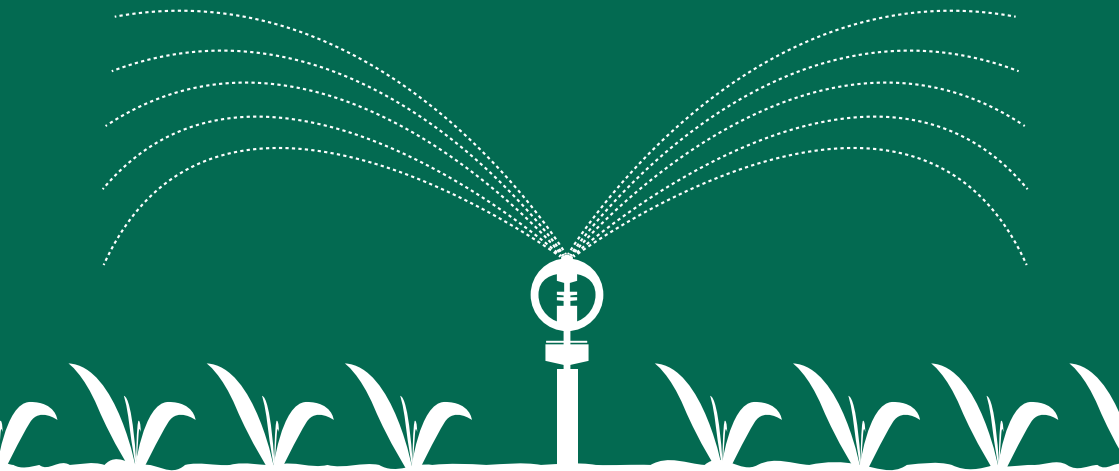

WATER APPLICATION

FACTORS INFLUENCING CHOICE/SELECTION OF APPLICATION SYSTEMS

Several factors influence the selection of different water application systems as detailed below

Capital Costs involved

The cost of system namely Purchase, installation, operation and maintenance play a big role in choice of application solution; Surface/flood irrigation usually is the cheapest mode followed by Sprinkler irrigation and Drip Is usually Most Costly

Efficiency and Uniformity.

The efficiency of application varies per technology with Surface/Flooding being least efficient while drip is most efficient

Soil type

Sandy soils have low water storage capacity and high infiltration rate, hence requiring frequent but small irrigation applications. Sprinkler and drip irrigation are more suitable on sandy soils as opposed to surface irrigation. All the three types of irrigation are suitable for loams and clays. Clay soils with low infiltration rates are suited to surface irrigation. When different soil types are found within an irrigation scheme, drip irrigation is preferred as it ensures even distribution of water.

Water quality

Surface irrigation is preferred if the irrigation water contains much sediments as they clog drip or sprinkler irrigation systems. Drip irrigation is suitable if the irrigation water contains dissolved salts as less water is applied to the soil than with surface methods. Sprinkler systems are more efficient than surface irrigation methods in leaching out salts.

Water quantity

The amount of water available for application is a key determinant in type of application system; with excess quantity available any mode would work but with water scarcity then drip irrigation is most appropriate mode

Type of Crop irrigated

The type of crop to be irrigated will determine the suitable type of application system. Some crops are suited for overhead irrigation while others are best suited for drip irrigation.

Tomatoes and Beans are best suited for drip irrigation as overhead / sprinkler application in tomatoes increases chances of occurrence of blight and other diseases while in beans it affects the flowers . Therefore for these crops the best suitable type application type is drip though due to the cost aspect, many farmers opt to use hoses & broken furrows as they are a form of localized application.

Other crops like Onions and garlic can grow well under overhead irrigation and also under drip irrigation, though drip irrigation is the best option because of high efficiency, sprinkler irrigation works well for these crops too.

MAIN IMPORTANCE:

- ✗ Crop production
- ✗ Efficient use of water resources

OTHER USES:

- ✗ Preventing soil compaction
- ✗ Protecting crops against frost
- ✗ Suppressing weed growth

Before selecting an irrigation method, the farmer should be aware of the advantages and disadvantages of the method of water application. The selected method must suit the local conditions and this will subsequently result in an increase in crop yields. Irrigation systems should be designed to maximize efficiencies and minimize labour and capital investments.

Water application methods can be classified based on:

- Energy/pressure required:** gravity irrigation and pressurized irrigation
- Placement of irrigation water:** whether on, above or below the soil surface
- Wetted area of crop root zone by irrigation:** flood, drip (trickle or localized), sprinkler.

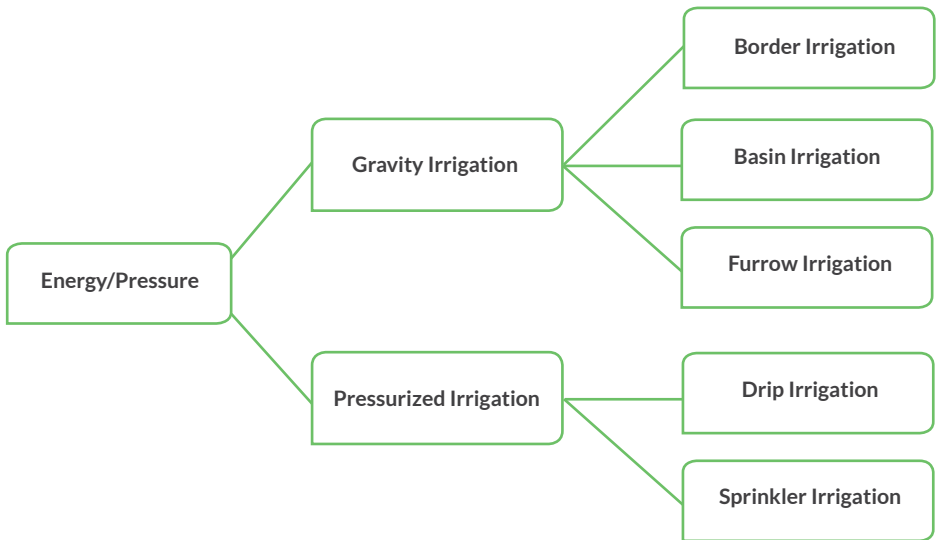

Figure 1: Water application classification - Energy/Pressure

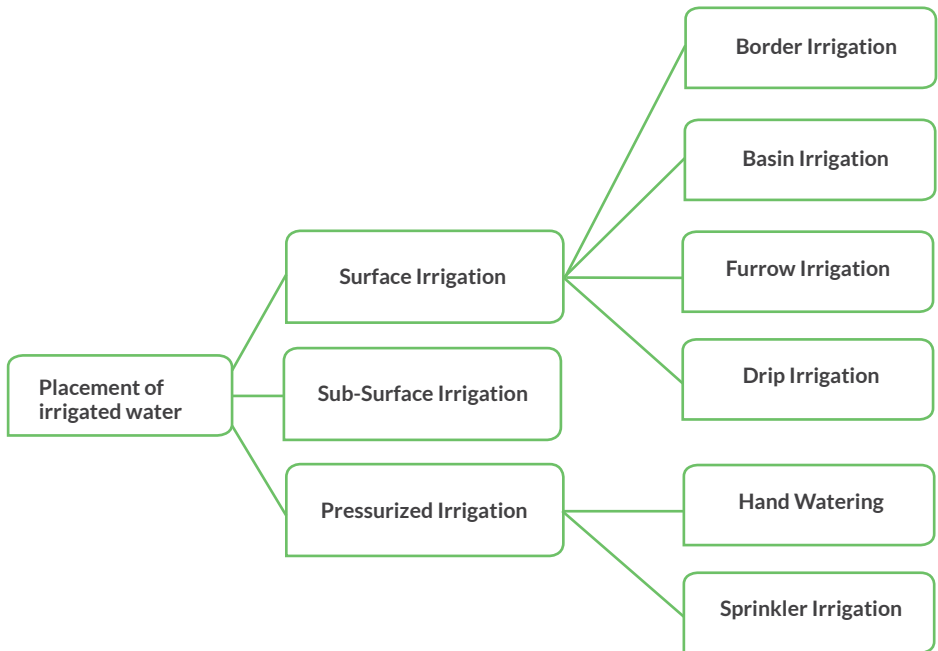

Figure 2: Water application classification - Water Placement

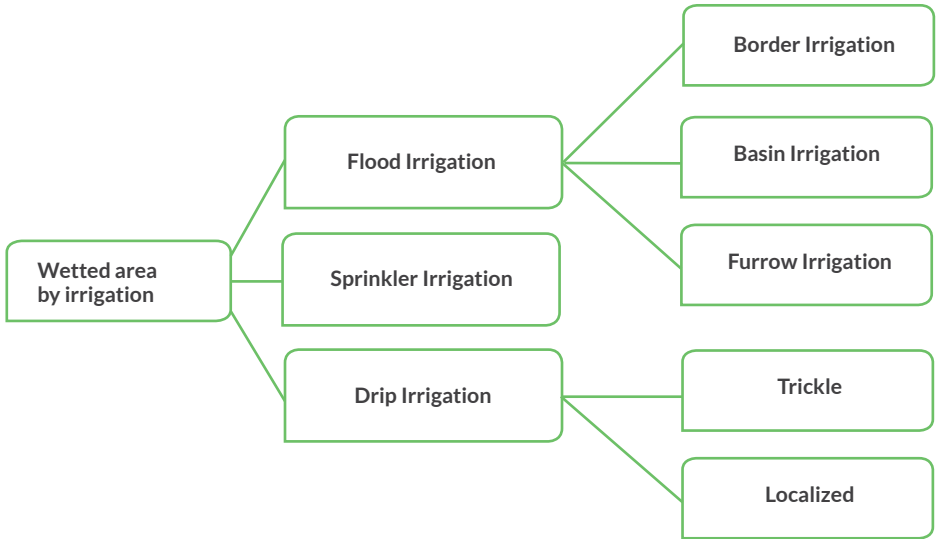

Figure 3: Water application classification - Wetted area by irrigation

Gravity Irrigation

Irrigation in which water flows and is distributed to the crop field without any pumping action

Pressurized Irrigation

Water is pumped and flows to the crop field through pumping/ by pressure.

Surface Irrigation

Irrigation method where the soil surface is used as a conduit

Subsurface/ Sub-Irrigation

An application method below the ground surface either by raising the water table within or near the root zone.

Border Irrigation

Application of water to an area typically downslope and surrounded by two border ridges or dikes to the end of the strip.

Basin Irrigation

Water application to an area typically levelled to zero slope and surrounded by dikes and banks to prevent runoff.

Furrow Irrigation

Partial surface flooding method of irrigation. Water is applied in furrows (narrow channels dug between the rows of crops) or rows as opposed to distributing water throughout the whole field.

Sprinkler Irrigation

Water is applied by means of a nozzle or perforated pipe that operates under pressure in the form of a sprat pattern.

Drip irrigation

Water is applied directly to the root zone of plants.

Flood irrigation

The entire soil surface of the field is covered by ponded water.

FACTORS AFFECTING SUITABILITY OF VARIOUS WATER APPLICATION METHODS:

a) Natural conditions – These include:

- **Soil type** – Sandy soils have low water storage capacity and high infiltration rate, hence requiring frequent but small irrigation applications. Sprinkler and drip irrigation are more suitable on sandy soils as opposed to surface irrigation. All the three types of irrigation are suitable for loams and clays. Clay soils with low infiltration rates are suited to surface irrigation. When different soil types are found within an irrigation scheme, drip irrigation is preferred as it ensures even distribution of water.
- **Slope** – Sprinkler or drip irrigation preferred on steep and uneven sloping land as little or no land levelling is required.
- **Climate** – Strong winds can disturb the spraying of water from sprinklers; drip or surface methods are hence preferred.
- **Water quality** – Surface irrigation is preferred if the irrigation water contains much sediment; sediments may clog drip or sprinkler irrigation systems. Drip irrigation is suitable if the irrigation water contains dissolved salts as less water is applied to the soil than with surface methods. Sprinkler systems are more efficient than surface irrigation methods in leaching out salts.

- **Water Quantity** – Water application efficiency is higher with sprinkler and drip irrigation than surface irrigation, hence preferred when water is in short supply.

b) Type of crop

Drip and sprinkler technology is mainly used for high value crops due to their high capital investment per hectare. Surface irrigation used for all types of crops. Drip is used mainly for crops grown in rows and not suitable for close growing crops e.g. rice.

c) Type of technology

Generally, drip and sprinkler irrigation are technically more complicated methods. Purchase, installation and maintenance are both an expensive venture. Surface irrigation systems require less sophisticated equipment for both construction and maintenance.

d) Previous experience with irrigation

Previously unknown irrigation technology leads to unexpected complications. Farmers may find it difficult to adopt new technology also depending on cost of technology.

e) Required labour inputs

Surface irrigation requires a much higher labour input for construction and maintenance than sprinkler or drip irrigation i.e. accurate land levelling, regular maintenance and high level of farmer organisation for system operation.

f) Costs and benefits

Cost considerations need to be made including construction, installation, operation and maintenance. Cost should be compared with expected benefits (yields).



IRRIGATION

G.DRIP KIT



This is a specially customized drip irrigation unit for both small and middle scale farmers with all the necessary components to facilitate controlled irrigation of crops in small to medium sized plots/gardens, with the sole purpose of conserving water and boosting crop yields.



USES

- ✘ The GDK is used for irrigation of small & medium plots, backyard gardens etc.
- ✘ For 1000 m² till 4000 m² of plot areas
- ✘ GDK is used for irrigation of vegetables, orchards, fruit trees, row crops and greenhouses.
- ✘ The GDK being gravity-based, does not require any energy source for its operation.
- ✘ GDK is suitable for all types of soils, climates and water sources.
- ✘ GDK is suitable for use in flat land or slight slopes.

GDK MAIN COMPONENTS

1 Water tank:



Will be made of any material capable of holding 200 liters and above. The water tank should have 1" outlet installed at minimal height of 15cm above tank's bottom. Also to be installed is a drainage outlet at the bottom of the tank to allow sediments to be washed out. The tank needs to be elevated at least 1M above the ground

2 Main Valve:



To be installed at tank's outlet.

3 Filter:



1" Screen filter



Note: screen filter is used where the irrigation water is clearer and has lower concentrations of sediments; otherwise, a disk filter would be used.

4 PE Pipe:



Distribution line connecting between tank and dripper lines.

5 Dripper lines:



Connected to distribution line by start connectors and is 30m maximum length.



PLOT PREPARATION FOR G. DRIP KIT INSTALLATION

- 1.) Verify that water source supplies plot's maximal daily requirement. For example 1m² of vegetables grown in dry, hot regions will require 5 -10 liters day at peak growth under highest temperatures.
- 2.) Place water tank at the highest point in case of sloped area within plot's boundaries.
- 3.) Mark plots boundaries, beds and spacing based on the specific crop grown maximal dripper line length will be 30m. It is possible to connect dripper lines on both sides of the distributor pipe.
- 4.) Mark distribution pipes location based on plot's structure.
- 5.) Prepare the land by ploughing, rotavating and bed shaping.



GDK INSTALLATION INSTRUCTIONS

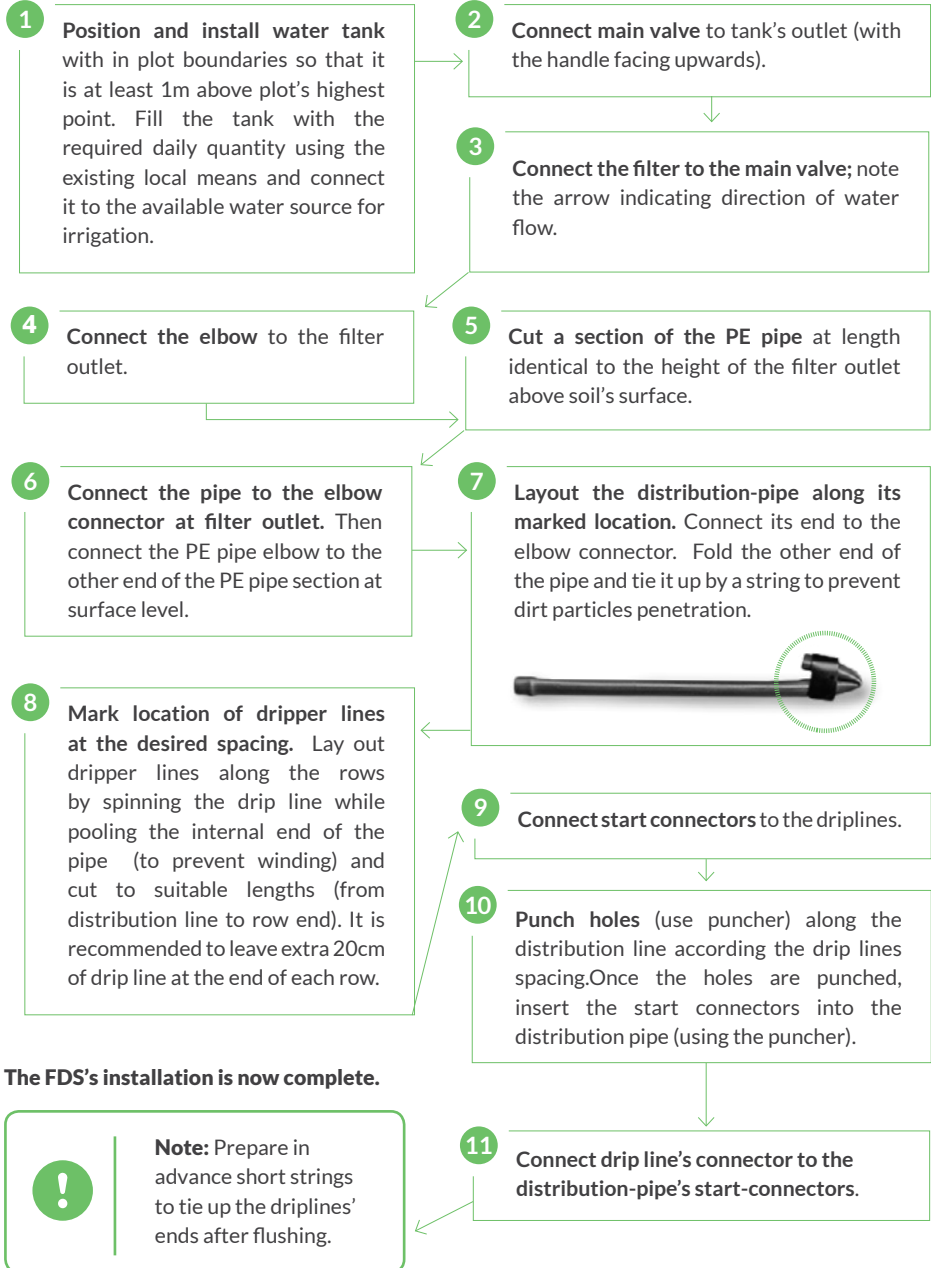

12

The installation is now complete.



ONCE SYSTEM IS INSTALLED

- 1.) Clean water tank of all sediments and residues. Fill it up to the top. Connect the system and leave distribution pipe and lateral's ends open!
- 2.) Flush the filter's screen with water (from the tank) and return to place.
- 3.) Open the main valve to flush distribution pipe for 5-10 minutes (until clear water flows out!). Fold pipe's end and tie it up.
- 4.) Flush dirt out of the driplines for a few minutes then fold driplines ends, starting with those closest to the water tank, and then tie them up one after the other as soon as clean water flows out.
- 5.) Once flushing is completed the system is ready for operation.



Remark:

While flushing the system it is recommended to ensure that water level in the tank is kept at maximal height to improve the efficiency of flushing.

MEDIUM AND LARGE SCALE FARM LAYOUT

This is where the farm is divided into blocks, for example blocks of $\frac{1}{4}$ acres and each block is irrigated per unit time (in most cases 45 min - 1hour).

It is composed of systems of surface and buried pipe system, main and sub main lines, hydrants, lateral lines and pipe risers to drip lines. These are demonstrated below;



A system of main pipe joining a tee junction that distributes water to the sub main lines on both sides.



A Lateral composed of pipe risers that will be connected to the driplines and a ball valve that controls the flow into the lateral.



A system serving four blocks

OPERATION

- 1 At the beginning of each irrigation shift, filter's screen must be flushed. The filter's screen must be well maintained to protect against tearing, therefore cleaning will be performed manually or with a very fine brush.
- 2 Once screen is returned to place and filter is closed, the system is ready for operation.
- 3 Open the main valve to operate the system.
- 4 Close the main valve at the end of irrigation.



MAINTENANCE

- ✘ **Filter cleaning** - every day before operation.
- ✘ In the event of dirty water it is recommended to clean the filter several times a day as required to maintain the screen clean and to ensure smooth water flow for adequate irrigation supply.
- ✘ **System flushing** - according to the specific water quality, at least once every two weeks (see flushing instructions).
- ✘ **System flushing at the end of irrigation season** - thorough flushing will be performed while shaking the drip lines to release and remove residues. After flushing, pipe and driplines should be drained before retrieval.
- ✘ Retrieval of pipe and laterals will be carefully performed to prevent damages.
- ✘ Ensure reels are stored in a dry place and protected against rodents or other damage).
- ✘ Main valve and filter will be drained and left to dry completely before storage. In the event of long-term storage, it is recommended to store the equipment either indoors or under shade.

ADVANTAGES OF DRIP IRRIGATION

AGRONOMICAL ADVANTAGES:

- Even water distribution throughout the field
- No water leaching below root system
- Prevention of evaporation from surface.
- No wind effect on water distribution
- Good soil aeration
- No wetting of foliage
- Leaching of salts out of root zone
- Reduced weed control
- Prevention of run-off

AGRO-TECHNICAL ADVANTAGES

- Low consumption of energy.
- Easy Cultivation.
- Low labor costs.
- Simplicity of operation



www.liquidleverkenya.com
Unblockable drip kits from back yard
to one acre and all gravity fed.

500 PLANT DRIP KIT

Irrigates approximately 500 plants using any water anywhere.

The 500 Plant Drip Kit is an efficient way to drip irrigate row crops on a plot of approximately 125 square metres. This kit is designed around our 'button emitter' layout which is a streamlined and efficient way to install and use your drip kit when compared with our 'tee-branch' layout.

We recommend you use a waterbutt or tank elevated to no more than 1 metre, with a capacity of not less than 250 litres for this kit. Water tank is not provided.

500 PLANT DRIP LAYOUT

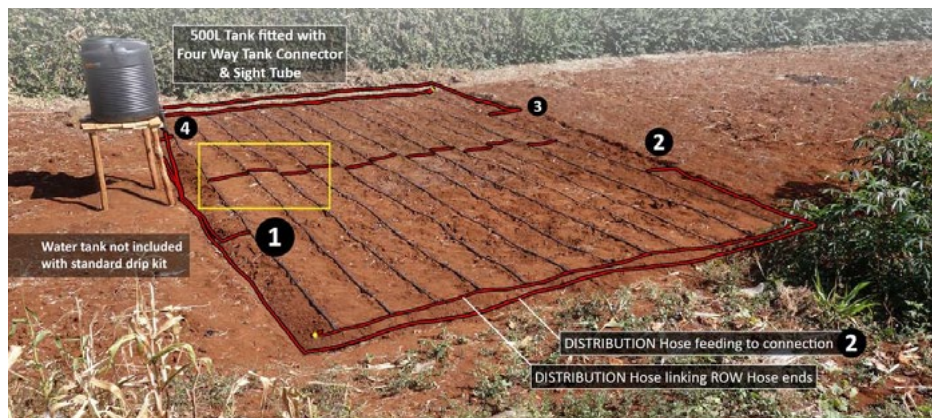

Note

1 - 4 Join the DISTRIBUTION Hoses to the ROW Hoses at the points shown (1-4). Not at the ends of the ROW Hoses. This will improve the distribution of water to the furthest away emitters.

 Ensure that the intermediate hose links are installed (detailed in the yellow boxes) to link the ROW Hoses and help distribute the water flow to the emitters.



The 500 Plant Drip irrigation kit can be extended to cover an $\frac{1}{8}$, $\frac{1}{4}$, $\frac{1}{2}$ and **1 acre**.



500 PLANT DRIP KIT





500 PLANT DRIP KIT COMPONENTS

500 Plant Drip kit	<ul style="list-style-type: none">✘ Four Way Tank Connector(Inc Brush and sight Tube- Qty- 1✘ Straight Connector (5mm Bore) - Qty 520✘ Adjusting Ring for SqueezeMe2 Emitter body - Qty 520✘ SqueezeMe2 Emitter Body - Qty 520✘ Straight Connector(13mm bore) - Qty 12✘ Elbow(13mm bore) - Qty 12✘ Tee (13 mm Bore) - Qty - 52✘ Black Distribution hose 26M coil(13mm bore) (Plain) – Qty3✘ Ground Stake(13 mm) - Qty 60✘ Slide Valve(13 mm) - Qty 8✘ Black row Hose 32m Coil (13 mm Bore)300 PITCH pre-Punched (8 metres spare length of hose) - Qty 5✘ End loop (Colour yellow) – Qty 8.
--------------------	---

BENEFITS

- ✘ Does not block or clog.
- ✘ Supports Fertigation
- ✘ Its Gravity Fed(No need for a pressure pump)
- ✘ Serviceable life span of 10 years.
- ✘ Can Be extended
- ✘ Allows Mixed planting
- ✘ No special tools needed to install.
- ✘ Can enable farmers in Arid and Semi Arid areas to farm using Our Drip irrigation Systems.
- ✘ Use any water any where
- ✘ Can be used both for green house farming or open farming.



Our systems are also used in greenhouses, shade nets, hydroponics and open fields.



INSTALLATION GUIDE

1 Pre-setting a SqueezeMe2 Emitter



For preset drip: Position the tab away from the hole in the SqueezeMe2 Emitter. Alternatively adjust the ring position to change the flow rate.



2 Assemble Button Emitter

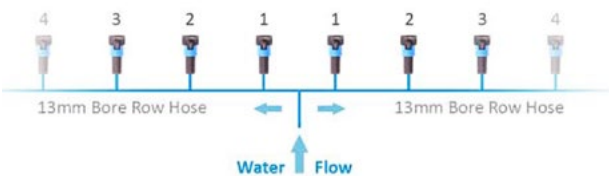

For individual emitter flow rates other than the preset flow rate (where the drip hole is exposed), adjust the emitters from the middle of the row out towards each end.



The SqueezeMe2 Supplementary Information



Setting Drip/Trickle Flow



1 - Maximum Flow - Occasionally you might want to use this setting - especially for larger plants and shrubs and where emitters are farthest from the water tank.



2 - Medium Flow - The blue tab is positioned so as not to cover the side hole. Suitable for medium sized plants and especially when fruiting. You can slide the blue collar forwards to further reduce the flow which will in most cases be a trickle.



3 - Minimum Flow - The blue tab is covering the side hole in the body and the blue adjusting ring is pulled forwards as far as possible. This will drip at the slowest rate. Recommended for small plants and for emitters close to the water tank.

Note: By popular demand the SqueezeMe2 Emitter is designed NOT to shut off completely.



Purging the Emitter

SqueezeMe2 Emitters are fully adjustable and designed to work with water from any source. Water-borne debris from the tank which blocks traditional emitters can be flushed out by sliding the adjusting ring backwards and squeezing the sides of the emitter body (see photo). This is crucial in areas where clean water is not available. SqueezeMe2 emitters can be reset, adjusted or dismantled for cleaning at any time.



3 Pipe Assembly



Connect one end of the hose to a **straight connector** and the other end to another pipe **OR** Cut the hose into lengths required to reach between the plants and join the hoses together with the connectors.

Elbow Joint Installation



Connect one end of the hose to a **Elbow** connector and the other end to another pipe **OR** Cut the hose into lengths required to reach between the plants and join the hoses together with the connector.



End Loop Installation

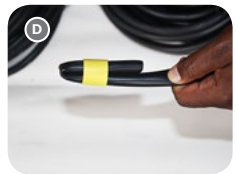

The **End Loop** can be placed over our Distribution Hose when doubled over to stop the water flow. Supplied as standard in the 200 and 300 drip kits.



4 Four way tank Connector installation

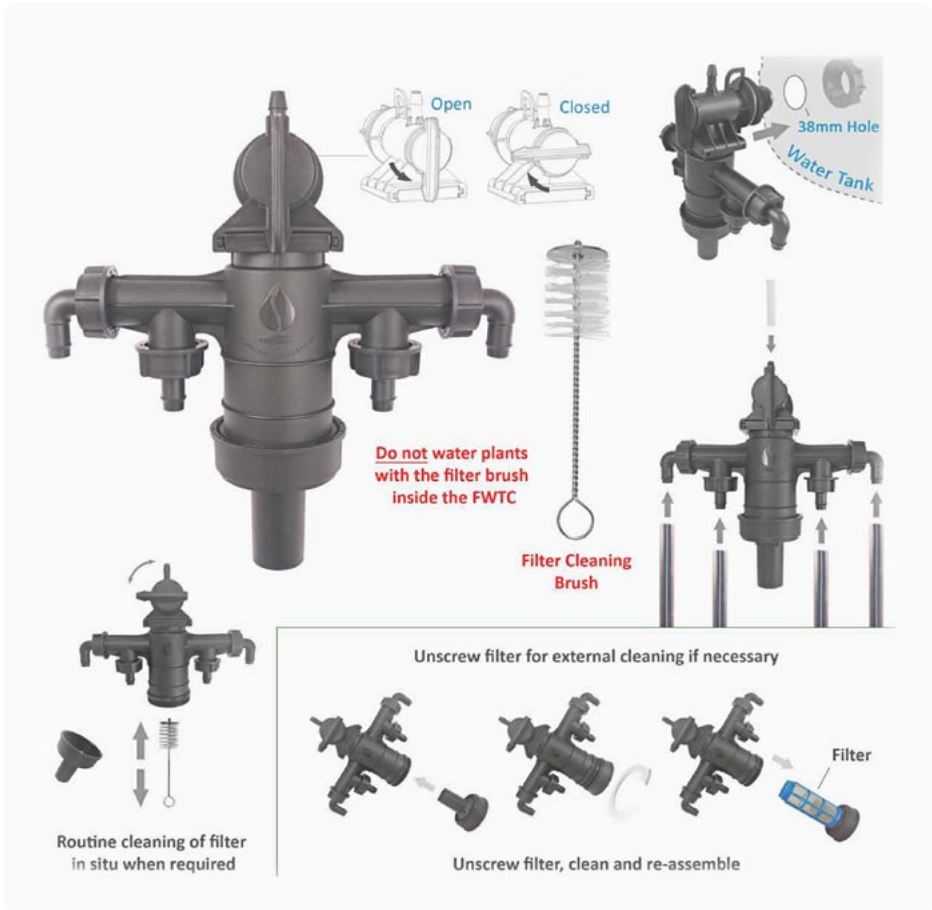

TO INSTALL connect up to four hose ends to the **Four Way Tank Connector (FWTC)** and connect this to a water tank. Cut the hose into lengths required to reach between the plants and join the hoses together with the connectors and connect the emitters to the free ends.

TO OPERATE Fill the tank (not supplied with water) and remove the Slide Valves to allow the water to flow to all of the emitters. Adjust the emitters to suit.



DO's

- Always follow the installation guide when installing the system.
- Always make sure that water used for irrigation is not muddy.
- Always make sure you use the right drill to drill a hole on your tank.
- In case of any challenge contact our agent or our office on the numbers provided for assistance.
- Ensure that you have a tank ready.
- Ensure that you have build or erected a stand that is 1 meter high before installation begins.



DON'T

- Do not use pipe wrench to tighten the components of our system.

OTHER SERVICES WE OFFER

Water harvesting and storage

Our range of products includes:

- Water silos from 50m³ to 3000m³
- Earth dams
- Pumping systems

Irrigation (drip & overhead irrigation)

- Unblockable drip irrigation systems
- Centre Pivots
- Rain guns,
- Lawn irrigation systems
- Green house structures
- Hydroponic Growing System & growing Medium
- Fertigation using biodigester slurry

Advisory and Management Services

- Better access to real time data
- Better extension services including soil testing and analysis
- Better access to quality inputs
- Better farming equipment

SOIL AND MOISTURE CONSERVATION



SOIL AND MOISTURE CONSERVATION

INTRODUCTION

There are always strong links between measures for soil conservation and measures for water conservation. Many measures are directed primarily to one or the other, but most contain an element of both. Reduction of surface run-off (conserving water) by structures or by changes in land management will also help to reduce erosion (conserving soils). Similarly, reducing erosion will usually involve preventing splash erosion, or formation of crusts, or breakdown of structure, all of which will increase infiltration, and so help the water conservation (FAO).

PRACTICES

Soils and water are essential ingredients to be able to grow crops, in farming therefore the conserving of both are very important. To do this a farmer will also either implicitly or consciously consider the meteorological factors affect crop growth and their interactions with both the soils and water he is managing. These factors include: temperature, relative humidity, sunshine (light intensity), rainfall and windspeed.

The practices presented underneath, consider the above-mentioned factors, in order to conserve both soils (including the nutrients in the soils) as well as available water (particularly rainfall).

Mulching



Mulch is applied to soil as a protective layer to manage the microclimate. Mulch can be organic material (wood, hay, leaves, needles, shells) or artificial (plastic, geotextile). Different mulch types serve different purposes at different locations. In general, mulch is used to reduce water loss through evapotranspiration, reduce weed growth, protect against heat and cold, and to add soil nutrients. Organic mulch in particular creates ideal conditions for beneficial insects (earth worms for instance) that improve soil quality, while discouraging other insects such as slugs. Mulch can be applied in all types of climate as long as an appropriate material is chosen.

'Soil mulching' is a specific type of mulching. In this technique, the soil pores are closed by 'planking'. A flat plank is moved either by tractor or animal traction over the soil to close soil pores and store the soil moisture inside.

Zai Pits



Zai planting pits consist of 'mini-basins' that store rainwater for plant growth and concentrate crop nutrients. Planting pits are excavated in grids. Planting pits of around 20cm in diameter and 10-15cm in depth may amount to 10,000-15,000 pits per hectare. Their dimension and density vary from area to area – depending on the crop grown, the soil conditions (they do not do well on hydroscopic soils for instance) and the need to harvest water. Larger pits and more spacing between them allow more water to be harvested.

The innovation developed through farmers experiments in Burkina Faso was to increase the depth and diameter of the pits and to add manure to them. Once excavated, the pits capture other material – for instance wind-blown soil and leaves. Termites are attracted to the organic material in the pits. They form an army of 'soil engineers'; digging small tunnels that improve the soil structure and cause water infiltration to double, convert organic material – and make nutrients available to the plant roots. The pits with the organic material will retain water in dry spells, allowing crops to survive. Sorghum is the preferred crop because of its adaptation to temporary inundation that may occur in the planting pit. Zai are well combined with stone contour bunds. These reduce the speed of runoff and allow even more retention of water and soil.

Stone Bunds / Lines



Stone bunds are built across slopes to slow down runoff and favour infiltration in the soil. They are built in series running along the slope. The bunds are semi-permeable, allowing the water to flow to the lower fields. The flow is distributed evenly and it decreases the risk of gully formation. Additionally, the stone barrier blocks and settles down the sediments transported from the upper slopes.

Fanya Juu / Contour Trenches



Fanya juu terrace systems have developed steadily in several parts of East Africa. One area where their spread has been spectacular is the Machachakos District in Kenya – where 85% of the land is now terraced. There are however several other areas where they are making an entrance. One area is the Makanya catchment in northern Tanzania. This catchment of 300 km² is part of the Pangani Basin. Its population still largely depends on subsistence agriculture and the area is characterized by high rainfall variability – ranging from 400 to 800 mm annually.

Rain comes in two seasons. The long season (masika) lasts from March till May, whereas the shorter season (vuli) is from October to December. The maximum rainfall for any season is 400 mm. With the amount of water often heavily constrained, conservation measures are of crucial importance to raise yields and provide food security. Conservation measures in Makanya include hand-hoeing, terracing, intercropping, small flow diversions and irrigation from micro-dams.

Intercropping



Intercropping simply means growing two or more crops at the same time in the same space. Growing a variety of crops together minimizes pest problems and makes efficient use of soil nutrients. Plants such as garlic, pepper, onion and basil repel some plant pests and can be planted between tomatoes, carrots or any other crop, as long as all plants have sufficient sunlight and space to grow properly.

Crops such as cowpea, groundnut, beans, bambara groundnut and other leguminous crops have roots that are able to make soil nitrogen available to other plants. Therefore, when such legumes are intercropped with other crops, particularly those that require plenty of nitrogen (e.g. young maize plants and sorghum), the non-legume crops benefit greatly. Another beneficial intercropping scenario would be to intercrop groundnut or beans with root crops such as cassava or yam.

Seed Dressing



Seed dressing or seed treatment is a chemical, typically antimicrobial or fungicidal, with which seeds are treated (or "dressed") prior to planting. Less frequently, insecticides are added. Seed treatments can be an environmentally more friendly way of using pesticides as the amounts used can be very small. It is usual to add colour to make treated seed less attractive to birds if spilt and easier to see and clean up in the case of an accidental spillage.



**NATURAL
INPUTS FOR
HEALTHIER
CROPS**

PANORAMIX

Panoramix is a seed dressing product based on beneficial microbial organisms. This is a new unique and innovative seed dressing product. It is used in arable crops such as maize, wheat, barley, etc.

These plant growth promoting micro-organisms colonize the roots and protect the crop during the entire growing season.



BENEFITS

- Improves crop vigor
- Boosts plant resilience and resistance to insufficient moisture and abiotic stress
- Increases nutritional value
- Promotes water use efficiency, reducing by up to 25% of total water requirement during the entire period of cultivation*
- Increases yields

*Results from SWA Innovation Project Trial Results

Recommended Application Rates

- Maize: 2ml per Kg of seed = to approx. 20ml/Acre (assuming 10 kg seed maize per acre)
- Wheat: 4ml per Kg of seed

APPLICATION PROCEDURE

1



Shake the product for about one minute and measure the right quantity of Panoramix

2



Put the seeds in a basin, bucket, drum or any other available mixing equipment and add Panoramix.

3



Mix for about five minutes until a uniform coating is achieved

4

Leave the seeds to dry in a cool place for about 20 - 30 minutes before planting or bagging. Sow the seeds immediately or in not more than 30 days.



VITIX

Vitix is a formulation of beneficial microbes which is used in horticultural crops for promoting plant growth and plant resilience.



BENEFITS

- The plant growth promoting micro-organisms in Vitix solubilize phosphorus and avail potassium and Silica which are essential nutrients for crop development
- Vitix acts as a catalyst that stimulates rooting in the early stages of the crop development which improves water and nutrient absorption
- The use of Vitix increases water efficiency and therefore reducing the amount of water used during the entire period of cultivation
- The benefits from the use of Vitix includes increased quality and quantity of crop yields which translates to increased income

Recommended Application Rates

- 45g per 20Litre water in the Nursery shortly after germination
- 1kg/Acre in the field shortly after transplanting

APPLICATION PROCEDURE

1



Fill the tank half the desired amount of water and start agitation.

2

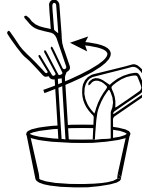

Mix the required amount of Vitix with a little water in a small container to make a slurry.

3



Slowly add the mixture to the tank while agitating.

4

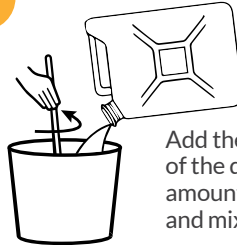

Add the remainder of the desired amount of water and mix thoroughly.

5



Apply immediately at the plant root zone by drenching.



CONTACTS AND OTHER INFORMATION RESOURCES

G. North Son



G. North & Son Limited
Mitchell Cotts Logistics Centre
P. O. Box 18114, 00500
Nairobi Kenya



+254 722 716 390 / 722 691 646
+254 2343 860



gsales@gnorth.co.ke
irrigation@gnorth



www.gnorth.co.ke



Lunga Lunga Plaza, Off Likoni Rd.
& Nairobi Jamhuri Showground.
P. O Box 49237-00100 Nairobi.



0709 751 476; 0733374 402
Direct Sales: 0708209843,
0710638471, 0734999400



sales@liquidleverkenya.com;
admin@liquidleverkenya.com



www.liquidleverkenya.com



Colours House, 3rd Floor, Office No:
301 Allsops, Outering Road; Nairobi,
Kenya



0720 949 555



Greenserve Agrisolutions



@Greenserve_Ag



info@greenserve.co.ke



www.greenserve.co.ke

Distribution centres

Sunlight Pump is distributed countrywide from our Nairobi sales centre. Contact us we link you with the regional distributor closest to you.

 Future pump

 0746 92 45 49

 Futurepump Ltd page

 www.futurepump.com

Where to repair & Distribution centres

All Davis and Shirliff outlets in Kenya.

All Suntransfer outlets in Kenya

All Solarnow outlets

Oasis Africa (Nairobi, Kitui)

Sidai Africa outlets



 49 Convent Road, Lavington,
Nairobi, Kenya

 + 254 700 327 002

 Sunculture

 sales@sunculture.com

 www.sunculture.com

Distribution centres

Our distribution points are available in Kerugoya, Mwea, Embu, Sagana, Muranga, Nanyuki, Thika, Machakos, Kitui, Wote, Kathonzeni, Matuu, Mlolongo, Kitengela, Mombasa, Nakuru, Elburgon, Eldama Ravine, Nyahururu, Eldoret, Kitale, Bungoma, Busia, Kakamega, Iten, Kisumu. All major towns to be covered soon!

 **KOPPERT**
BIOLOGICAL SYSTEMS

 Apex Business Park, Mombasa Rd.
P. O. Box 41852-00100 Nairobi,
Kenya

 +254 20 44537804

 Koppert Kenya

 info@koppert.co.ke

 www.koppert.co.ke

 **PRACTICA**
FOUNDATION

 Geulweg 16
3356 LB Papendrecht
The Netherlands

 www.practica.org

 **SNV**

 Ngong Lane, off Ngong Road
P. O. Box 30776, 00100
Nairobi, Kenya

 Tel.: +254 724 463355

 Email: kenya@snv.org



SNV